

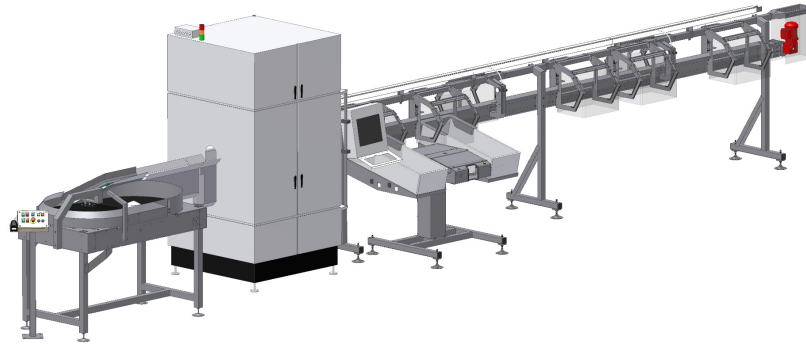

HLZ MD High-speed Counting and Sorting Machine



PATENT
PENDING

<i>Product description</i>	Industrial high-speed counting and sorting machine for handling of non-refillable used beverage containers
<i>Container type</i>	PET bottles, aluminium cans, steel cans, glass bottles Maximum glass fraction 20%
<i>Container shape</i>	Cylindrical Diameter: 50 - 130 mm Length: up to 400 mm
<i>Bar codes</i>	EAN/UPC Magnification ratio 80-150%
<i>Detection method</i>	360° detection of bar codes and security marks
<i>Capacity</i>	80-100 beverage containers/minute
<i>Registration accuracy</i>	≥ 99.5%
<i>Infeed</i>	Mini bulk feeder of a volume of 300 litres (not illustrated)
<i>Inliner module</i>	Mono Disc
<i>Sorting stations</i>	Customer-specific number of sorting stations Optional: 1 no-read station
<i>Power consumption</i>	Approx. 1.5 kW 3 phase voltage + N + PE
<i>Network</i>	A LAN for transmission of counting data files and a LAN for HLZ EazyVPN for remote support and trouble shooting
<i>Dimensions</i>	Approx. 11.0 x 2.6 x 1.8 metres (LxHxW) depending on the length of the sorting line
<i>Compressed air</i>	Consumption of approx. 12 m ³ per hour at 8 bar
<i>Approval</i>	CE or UL/CSA

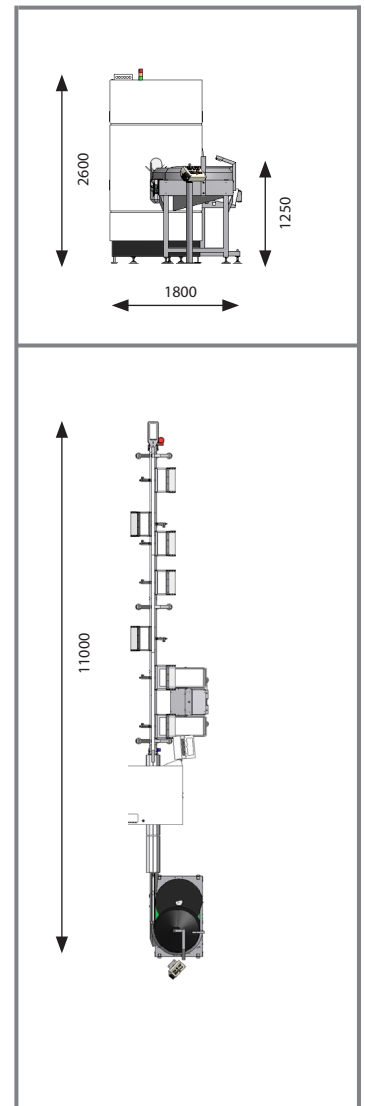

www.anker-andersen.com

Anker Andersen A/S
Anker Andersens Vej 1
DK- 7160 Tørring
Tel: +45 7033 2233